

tentative

Standard Rectifier Module

$$V_{RRM} = 2 \times 1800 \text{ V}$$

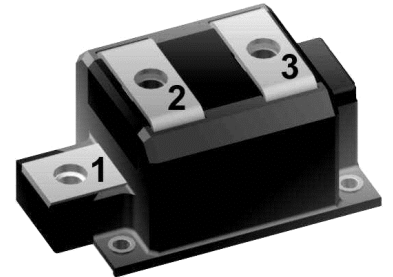
$$I_{FAV} = 700 \text{ A}$$

$$V_F = 1.05 \text{ V}$$

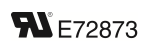
Phase leg

Part number

MDMA700P1800CC



Backside: isolated




Features / Advantages:

- Package with DCB ceramic
- Improved temperature and power cycling
- Planar passivated chips
- Very low forward voltage drop
- Very low leakage current

Applications:

- Diode for main rectification
- For single and three phase bridge configurations
- Supplies for DC power equipment
- Input rectifiers for PWM inverter
- Battery DC power supplies
- Field supply for DC motors

Package: ComPack

- Isolation Voltage: 4800 V~
- Industry standard outline
- RoHS compliant
- Base plate: Copper internally DCB isolated
- Advanced power cycling
- Phase Change Material available

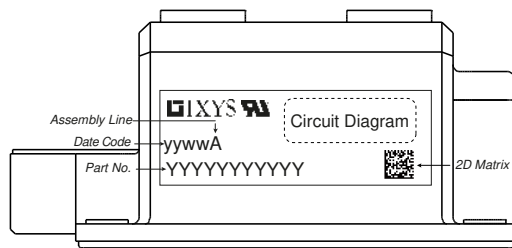
Disclaimer Notice

Information furnished is believed to be accurate and reliable. However, users should independently evaluate the suitability of and test each product selected for their own applications. Littelfuse products are not designed for, and may not be used in, all applications. Read complete Disclaimer Notice at www.littelfuse.com/disclaimer-electronics.



Rectifier				Ratings			
Symbol	Definition	Conditions		min.	typ.	max.	Unit
V_{RSM}	max. non-repetitive reverse blocking voltage					1900	V
V_{RRM}	max. repetitive reverse blocking voltage					1800	V
I_R	reverse current	$V_R = 1800$ V		$T_{VJ} = 25^\circ\text{C}$		500	μA
		$V_R = 1800$ V		$T_{VJ} = 150^\circ\text{C}$		20	mA
V_F	forward voltage drop	$I_F = 700$ A		$T_{VJ} = 25^\circ\text{C}$		1.14	V
		$I_F = 1400$ A				1.35	V
		$I_F = 700$ A		$T_{VJ} = 125^\circ\text{C}$		1.05	V
		$I_F = 1400$ A				1.30	V
I_{FAV}	average forward current	$T_C = 100^\circ\text{C}$ rectangular	$d = 0.5$	$T_{VJ} = 150^\circ\text{C}$		700	A
V_{F0}	threshold voltage	} for power loss calculation only				0.78	V
r_F	slope resistance					0.35	m Ω
R_{thJC}	thermal resistance junction to case					0.055	K/W
R_{thCH}	thermal resistance case to heatsink			0.02			K/W
P_{tot}	total power dissipation			$T_C = 25^\circ\text{C}$		2270	W
I_{FSM}	max. forward surge current	$t = 10$ ms; (50 Hz), sine		$T_{VJ} = 45^\circ\text{C}$		20.0	kA
		$t = 8,3$ ms; (60 Hz), sine		$V_R = 0$ V		21.6	kA
		$t = 10$ ms; (50 Hz), sine		$T_{VJ} = 150^\circ\text{C}$		17.0	kA
		$t = 8,3$ ms; (60 Hz), sine		$V_R = 0$ V		18.4	kA
I^2t	value for fusing	$t = 10$ ms; (50 Hz), sine		$T_{VJ} = 45^\circ\text{C}$		2.00	MA ² s
		$t = 8,3$ ms; (60 Hz), sine		$V_R = 0$ V		1.94	MA ² s
		$t = 10$ ms; (50 Hz), sine		$T_{VJ} = 150^\circ\text{C}$		1.45	MA ² s
		$t = 8,3$ ms; (60 Hz), sine		$V_R = 0$ V		1.40	MA ² s
C_J	junction capacitance	$V_R = 400$ V; $f = 1$ MHz		$T_{VJ} = 25^\circ\text{C}$		781	pF

Package ComPack		Ratings				
Symbol	Definition	Conditions	min.	typ.	max.	Unit
I_{RMS}	RMS current	per terminal			1200	A
T_{VJ}	virtual junction temperature		-40		150	°C
T_{op}	operation temperature		-40		125	°C
T_{stg}	storage temperature		-40		125	°C
Weight				500		g
M_D	mounting torque		3		5	Nm
M_T	terminal torque		12		14	Nm
$d_{Spp/App}$	creepage distance on surface striking distance through air	terminal to terminal	21.0			mm
$d_{Spb/Apb}$		terminal to backside	18.0			mm
V_{ISOL}	isolation voltage	t = 1 second	4800			V
		t = 1 minute	4000			V


Part description

- M = Module
- D = Diode
- M = Standard Rectifier
- A = (up to 1800V)
- 700 = Current Rating [A]
- P = Phase leg
- 1800 = Reverse Voltage [V]
- CC = ComPack

Ordering	Ordering Number	Marking on Product	Delivery Mode	Quantity	Code No.
Standard	MDMA700P1800CC	MDMA700P1800CC	Box	3	

Equivalent Circuits for Simulation

* on die level

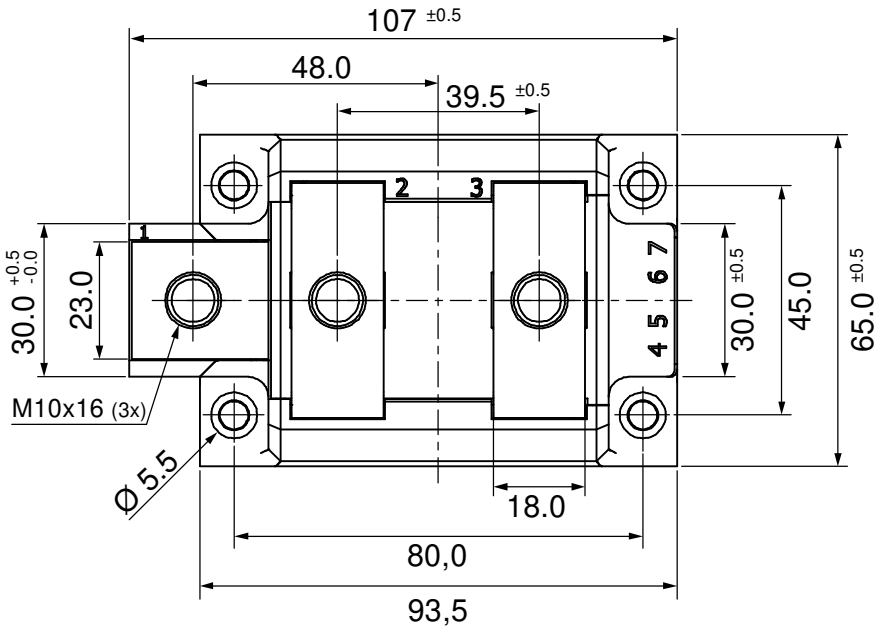
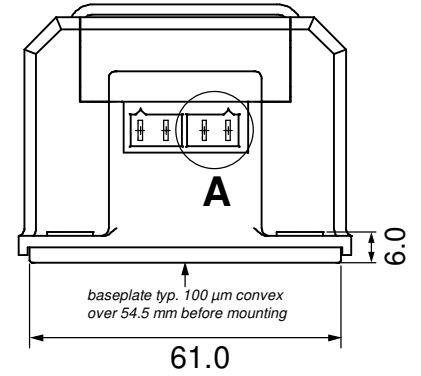
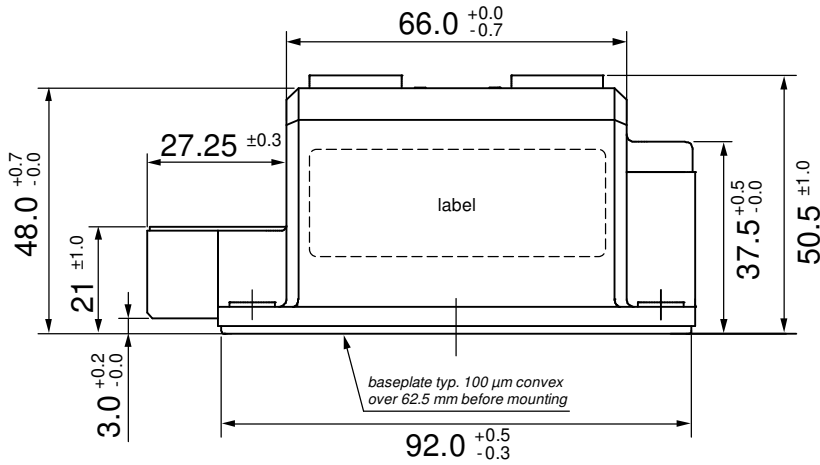
 $T_{VJ} = 150^{\circ}\text{C}$

Rectifier

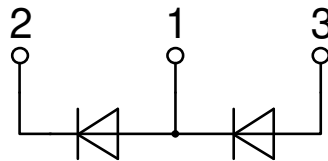
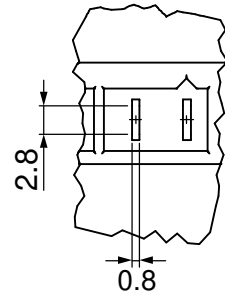
$V_{0\ max}$	threshold voltage	0.78	V
$R_{0\ max}$	slope resistance *	0.16	mΩ



Outlines ComPack



A (2:1)



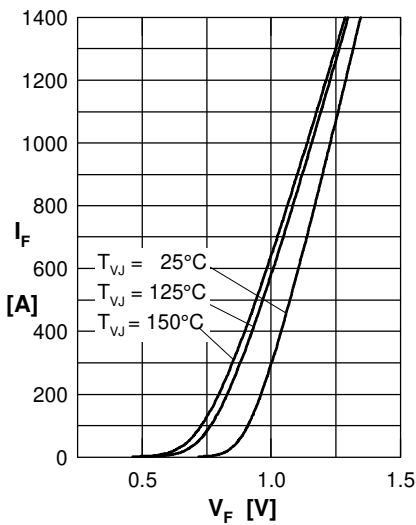
Rectifier


Fig. 1 Forward current versus voltage drop per diode

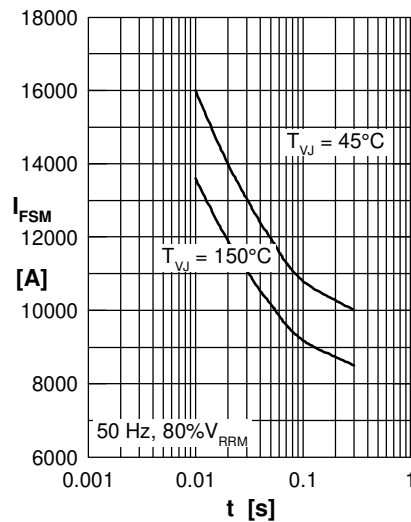


Fig. 2 Surge overload current vs. time per diode

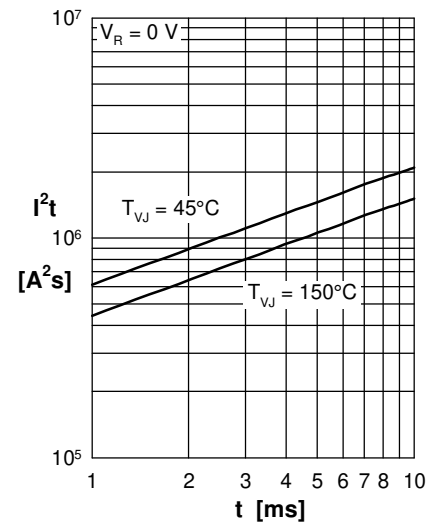
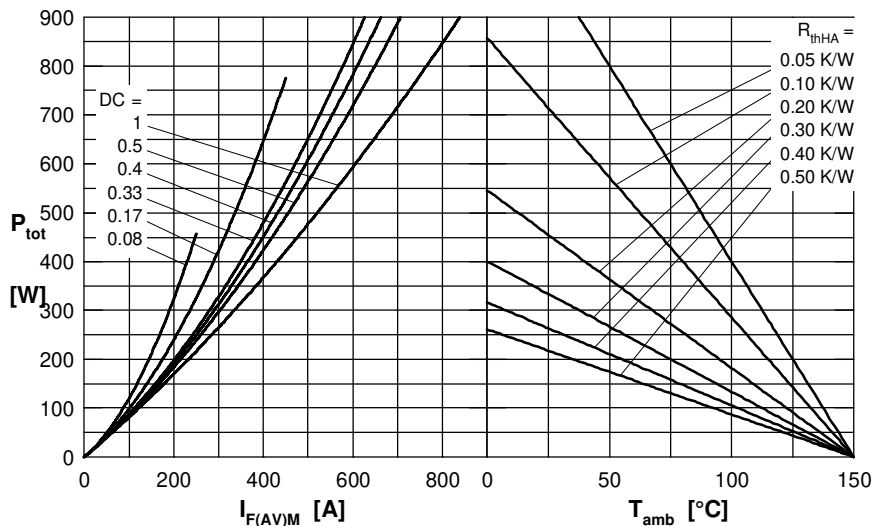

 Fig. 3 I^2t versus time per diode


Fig. 4 Power dissipation vs. forward current and ambient temperature per diode

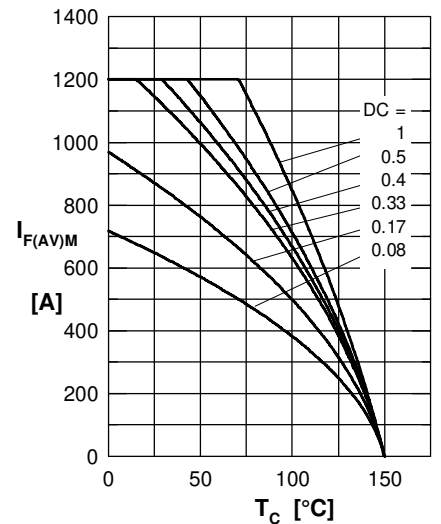


Fig. 5 Max. forward current vs. case temperature per diode

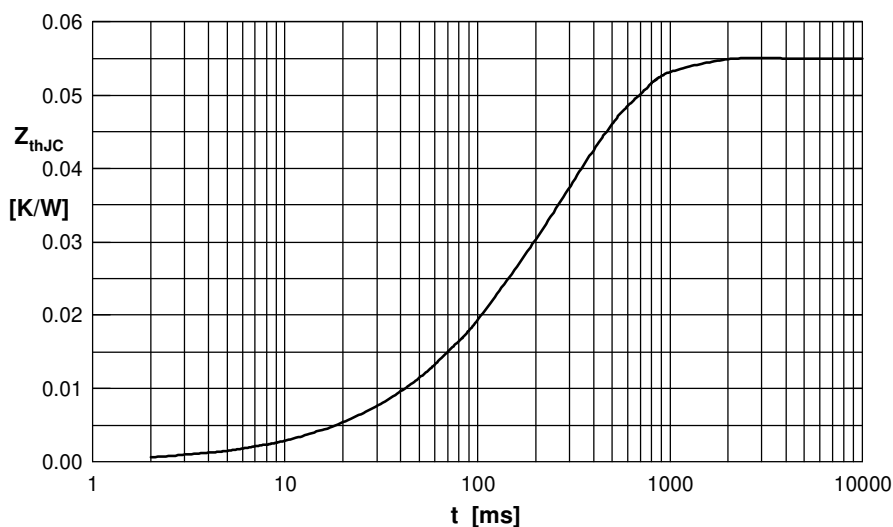


Fig. 6 Transient thermal impedance junction to case vs. time per diode

 Constants for Z_{thJC} calculation:

i	R_{thi} (K/W)	t_i (s)
1	0.001	0.0150
2	0.004	0.0600
3	0.017	0.2000
4	0.033	0.3400